

MELT MANIFOLD PARTS IDENTIFICATION DIAGRAM

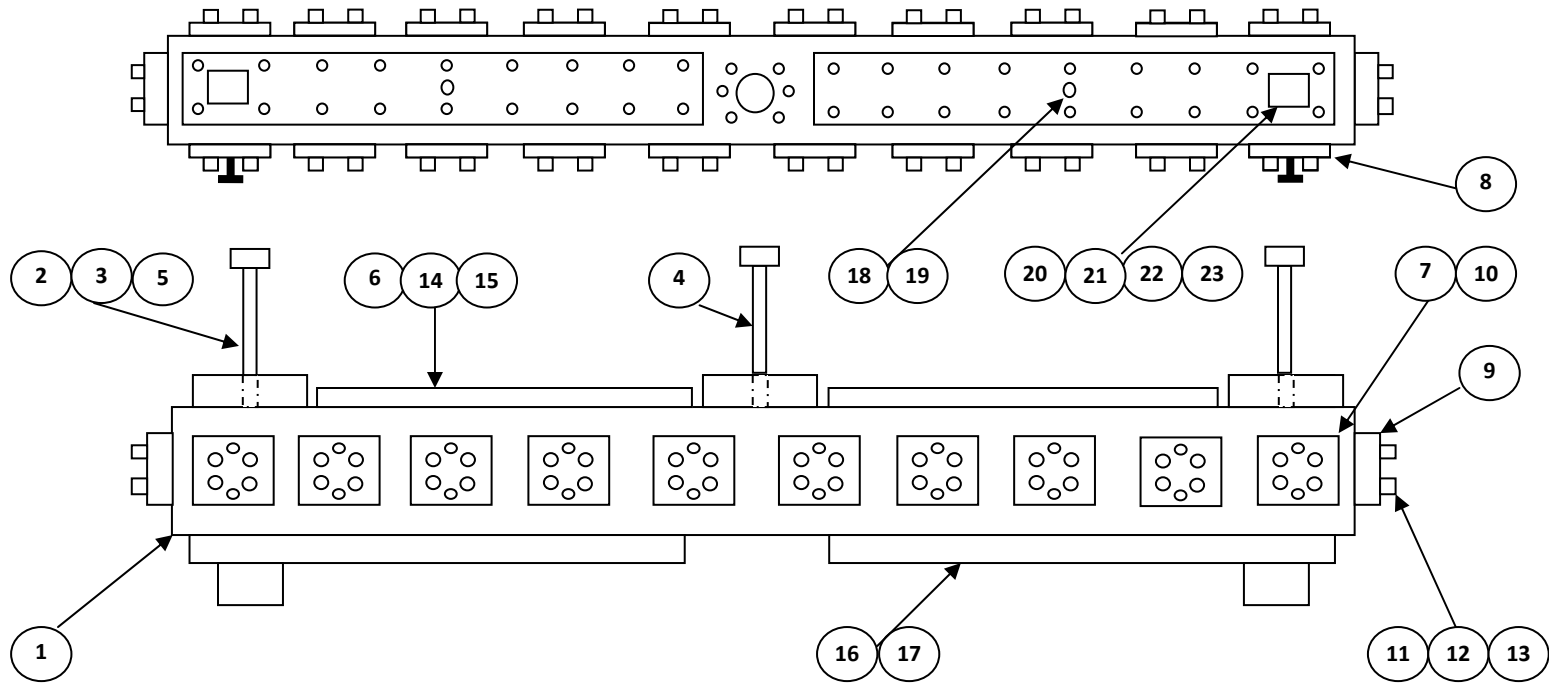

#	Part Number	Description	#	Part Number	Description
1	111XXX	Melt Manifold	14	102267	BHCS 1/4"-20
2	111113/S	Manifold Spacer STD/Steel (3x)	15	102269	1/4" Washer
3	111001	Manifold Mounting Bolts – outboard (2x)	16	160055-66	Plate Heater Determined by design
4	111002	Manifold Locating Bolt – Center	17	102265	3/8"-16 SHCS (36)
5	111003	T-Nut (2x)	18	104130	T/C Adapter (2)
6	111101	Backside insulator pad set (2x)	19	104144/141	Bayonet End T/C (2)
7	111129	Manifold Cap (# HOLES)	20	103164	90° Strain Relief Wire Connector (2)
8	111137	Manifold Bleed Cap (2x)	21	103165	Anti Short Bushing (2)
9	111131	Manifold Plug (2x)	22	103166	SS Armor Cable – Cord wrap (12)
10	107165	Seal Ring (# HOLES +2)	23	103150	Hi Temp Wire (24)
11	102262	SHCS 1/2"-13 – Hardened (# HOLES +14)			
12	102263	1/2" Flat Washer – Hardened (# HOLES + 14)			
13	102264	1/2" Lock Washer – Hardened (# HOLES + 14)			